

PTFE expansion joint - Type P-1

Universal expansion joint DN 15 – DN 500



Structure type P-1

Universal expansion joint consisting of PTFE bellows with rotatable flanges

PTFE bellows PN 5.5 / PN 9 / 10.5

- Multiple convolution bellows made of PTFE
- Outer supporting rings of stainless steel between the convolutions
- Bellows with self-sealing PTFE flange ends
- Inner surface repellent of foreign matter

Material quality*	Possible uses
PTFE	Aggressive acids and lyes, e.g., chloride, sulphate, solvents, bleaches, peroxide, fuels

*Check or inquire about the resistance of the material quality to temperature and medium

DN	DN 200 - 500	DN 125 - 150	DN 15 - 100	Temperature
Pressure rate	PN 5.5	PN 9	PN 10.5	
max. tol. operating pressure	5.5 bar	9.0 bar	10.5 bar	up to +20 °C
	3.5 bar	5.5 bar	7 bar	up to +100 °C
	2.5 bar	4.0 bar	4 bar	up to +150 °C
	1.7 bar	2.5 bar	3 bar	up to +200 °C
Vacuum operation	≥ 0.01 bar abs. DN 15 - 150 ≥ 0.20 bar abs. DN 200 - 250 ≥ 0.70 bar abs. DN 300 - 500			

Max. operating pressure should be set 30 % lower for shock load

Flanges

Version

- Rotable flange
- threaded holes

Dimensions

Standard: DN 25 - 150 (PN 16)
 DN 200 - 500 (PN 10)
 according to EN 1092
 Others: DIN EN, ANSI, BS etc.
 Connection dimensions: see technical annex

Materials

Standard: 1.0038 (S235JR)
 Others: 1.4541, 1.4571

Corrosion protection

Standard: DN 15 - DN 300
 electrogalvanized
 DN 350 - DN 500
 anti-corrosion primed
 Others: hot-dip galvanized, special varnish, special coatings

Applications

- for conveying aggressive media
- for compensating axial, lateral and angular movements
- for muffling vibration and noise
- for reducing thermal and mechanical tension
- to compensate for installation inaccuracies
- chemical industry
- treatment and disposal technology
- pharmaceutical industry

Accessories

- Internal guide sleeve of PTFE
- Protective cover

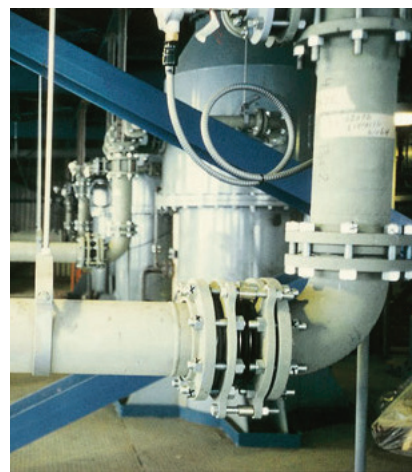

STENFLEX® type P1 in disposal pipes for chloro-electrolysis

Dimensions standard program

DN	BL	Pressure rate	ø di	ø C	PN	ø D	b	H
	mm	bar	Bellows inner ø mm	Raised face ø mm	Flange connection EN 1092	Flange outer ø mm	Flange thickness mm	Flange height mm
15	46	10.5	21.5	45	16	95	8	143
20	46	10.5	21.5	58	16	105	8	153
25	46	10.5	21.5	68	16	115	8	163
32	46	10.5	34.5	78	16	140	10	194
40	46	10.5	34.5	88	16	150	10	204
50	56	10.5	48.3	102	16	165	12	219
65	77	10.5	58.5	122	16	185	12	239
80	77	10.5	73.2	138	16	200	12	267
100	91	10.5	99.3	158	16	220	15	287
125	111	9.0	123.0	188	16	250	15	330
150	101	9.0	147.8	212	16	285	18	370
200	137	5.5	205.1	268	10	340	20	460
250	200	5.5	256.6	320	10	395	22	515
300	196	5.5	280.5	370	10	445	25	605
350	215	5.5			10			
400	233	5.5	on request	on request	10	on request	on request	on request
450	280	5.5			10			
500	327	5.5			10			

Larger DN's other structural lengths, higher pressures, other movement absorption available on request. Dimensions according to GR 12-0040 standard available on request.

Movement compensation / bellows cross section at area

DN	Δ ax	C _{ax}	Δ lat	Δ ang	A*	Weight
	Axial movement	Axial recoil rate	Lateral movement	Angular movement	Effective bellows cross sectional area	
	± mm	N/mm	± mm	± ∠ degrees	cm ²	approx. kg
15	6	18	4	14	3	1.7
20	6	18	4	14	5	1.7
25	13	18	6	14	10	1.7
32	13	38	6	14	19	2.1
40	13	44	6	14	19	2.6
50	15	57	9	14	30	3.8
65	19	81	9	14	45	4.6
80	25	98	13	14	70	5.3
100	25	107	13	14	112	7.0
125	25	118	14	14	166	11.4
150	28	112	14	14	245	12.7
200	28	123	14	14	400	21.0
250	30	116	14	14	660	27.0
300	30	107	15	14	770	35.0
350	32	on request	18	14	on request	60.0
400	35		20	14		75.0
450	30		20	14		91.0
500	30		25	14		110.0

Please inquire for simultaneous (different) movement
Table values refer to +20 °C and triple convoluted expansion joints
*Effective bellows cross sectional area is a theoretical value.

Note

Additional PTFE seals necessary for installation in glass, graphite or ceramic pipes.

Type P1 is equipped with 3 check screws as transportation protection and to guarantee flawless installation. These are not impact-, or force-absorbing parts along the lines of tie rods, and must be removed after completing installation.

Please comply with general technical instructions regarding reaction force, adjusting force, fixed point load, installation instructions etc.

Subject to technical alterations and deviations resulting from the manufacturing process.

Version

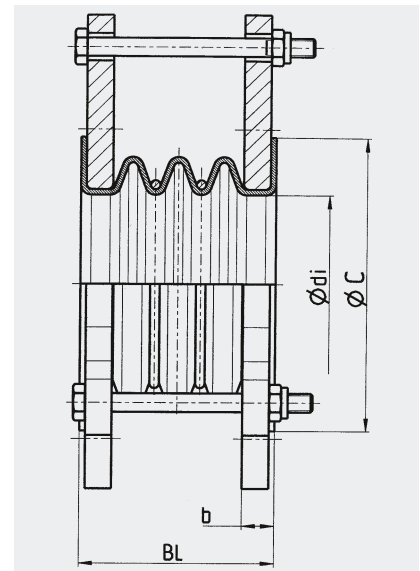

Type P-1
Universal PTFE expansion joint with transportation safeguard

Flange version

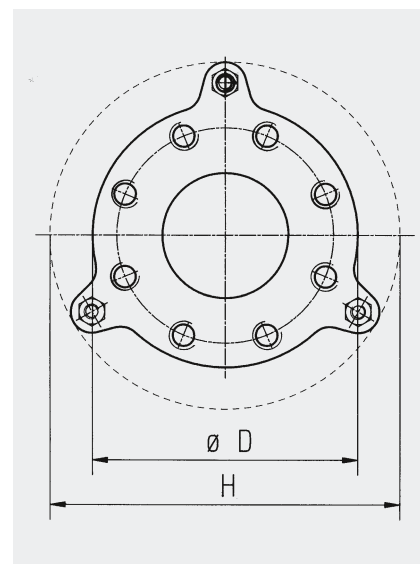

Molded ears for restraint as transportation safeguard only